

Saalasti Crush V

The heavy-duty rotor hog

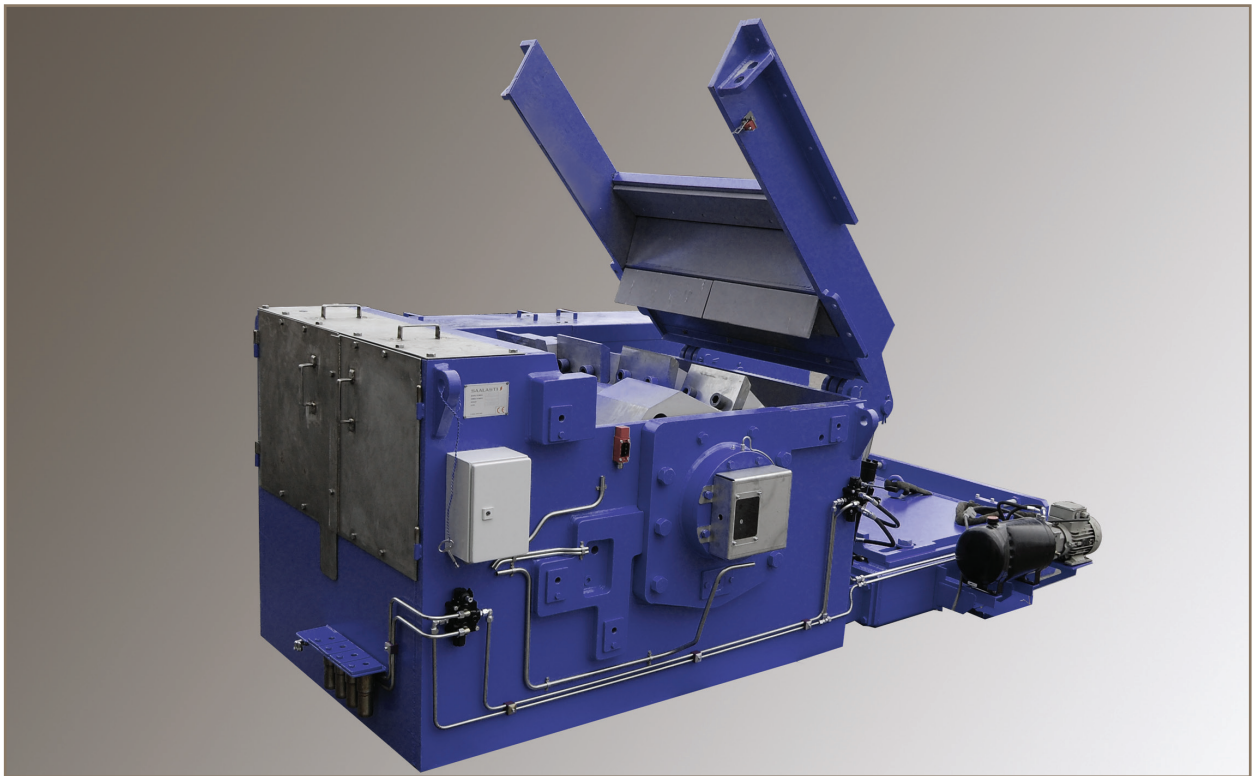

Saalasti has delivered over 100 crushers to pulp and paper mills and sawmills all over the world. Materials that are processed include everything from wood wastes to eucalyptus bark. The pictured crusher is 0909 V, one of the smallest models of Saalasti.

Robust and reliable

The Saalasti Crush V has one moving part, a rotor machined out of solid steel. A hog could not be more simple, robust and reliable. The Saalasti Crush V is specially adapted to a pulp mill environment.

Operation

The material to be hogged is first subjected to strikes from the big cutter bars of the solid steel rotor. During the final sorting stage the material is reduced to the required particle size between the crusher bars and the grate. Only pieces of desired size can come out of the grate holes. Larger pieces are broken when they get caught between the hole edge and the crusher bar.

Safe

Saalasti Crush V has the best possible overload protection in the form of special shear pins. If large metal pieces enter the machine, the shear pins break and release the anvil and the grate. The limit switches connected to the anvil and grate stop the electric motor.

Rebuildable wear parts

The wear parts of the machine are the anvil, grate and crusher/cutter bars, all of which can be rebuilt and reused. They are also available in several configurations to suit the particular case. The actual spare part requirement is low as the hog is so robust and heavy-duty that most of the parts simply can not be broken.

Technical data

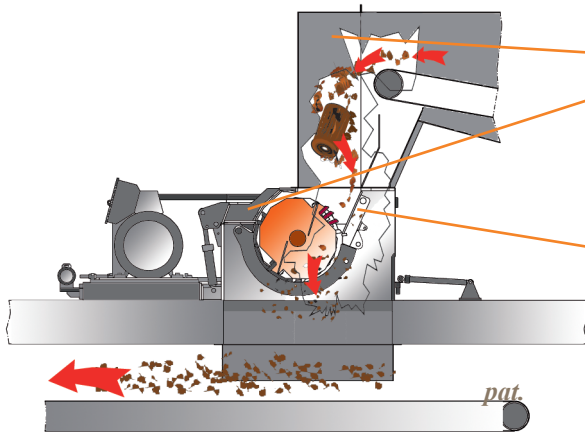

Service

The service is started by hydraulically opening the upper part of the frame.

This enables access to all wear parts and as well the infeed conveyor end pulley.

Anvil can be serviced from the top or through the front doors. There is a hydraulic cylinder for retrieving the anvil after safety pin breakage or for moving it to service position

A suitable hog for all needs

Saalasti manufactures the machine in several sizes for material flows up to over 300 m³/h. The Saalasti Crush V series hogs are typically used to shred bark, also eucalyptus bark in minor applications and unshredded or coarse hog fuel in receiving stations and pelletizing and gasifying applications. The final particle size can be chosen from P45 to P100 (mm) with P63 being the typical choice for boiler applications. The particle size is defined according to the ISO-17225-1_2014(E).

Saalasti Crush 0912 V

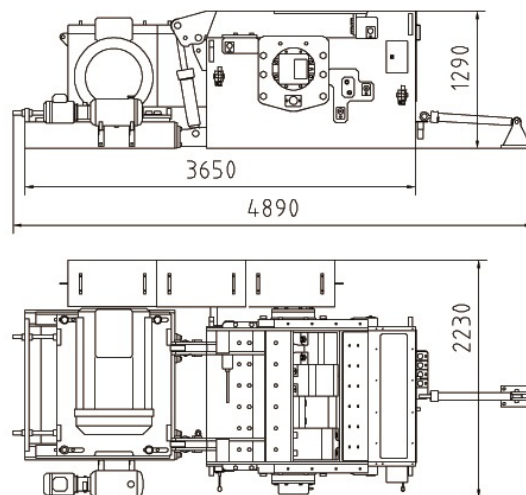

Saalasti Crush V

		0906	0909	0912	0915	1212	1215
Rotor diameter	mm	900	900	900	900	1200	1200
Rotor width	mm	600	900	1200	1500	1200	1500
Length, overall	mm	4890	4890	4890	4890	5870	5870
Width, overall	mm	1840	2140	2230	2530	2240	2540
Frame width	mm	712	1010	1308	1606	1308	1606
Height, overall	mm	1290	1290	1290	1290	1560	1560
Infeed opening width	mm	620	918	1216	1514	1216	1514
Infeed opening length	mm	695	695	695	695	875	875
Outfeed opening width	mm	620	918	1216	1514	1216	1514
Outfeed opening length	mm	1870	1870	1870	1870	2320	2320
Overall weight (without motor)	kg	8500	10000	11500	13500	17500	20000
Motor power, typical	kW / 1500 rpm	160	200	250	315	355	400
Rotor rotating speed	rpm	900	900	900	900	700	700
Production, particle size P100 mm	m ³ , loose vol/h	60	100	135	170	220	270
Production, particle size P100 mm	t/h, fresh	15	25	33	40	55	65

Saalasti Oy

Juvan teollisuuskatu 28, 02920 Espoo, Finland
 Tel (sales) +358-9-25115555 (office) +358-9-2511550
 sales@saalasti.fi, info@saalasti.fi, www.saalasti.fi

SAALASTI